



**DWARF
CONNECTION**



DC-LINK

MANUAL - ENGLISH

**LR2
ULR1**

Contents

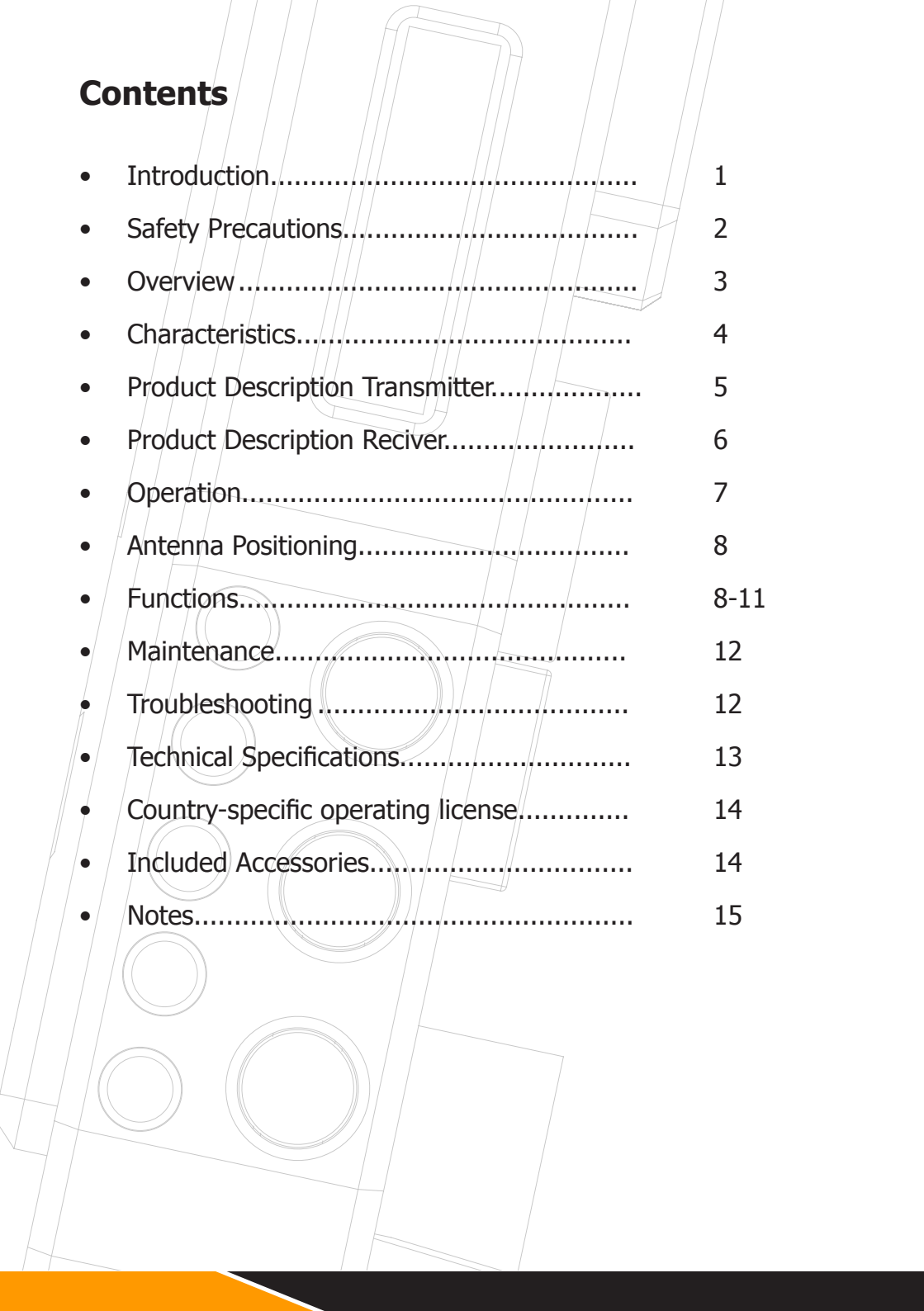

• Introduction.....	1
• Safety Precautions.....	2
• Overview.....	3
• Characteristics.....	4
• Product Description Transmitter.....	5
• Product Description Receiver.....	6
• Operation.....	7
• Antenna Positioning.....	8
• Functions.....	8-11
• Maintenance.....	12
• Troubleshooting.....	12
• Technical Specifications.....	13
• Country-specific operating license.....	14
• Included Accessories.....	14
• Notes.....	15

Introduction

Congratulations on purchasing the DC-Link video transmission system. Please read this manual carefully before operating your product, and ensure it is kept in a safe place.

The technology contained in this product, including the device itself as well as related software and trademarks, is protected by law. Any duplication or reproduction without the written permission of the copyright owner is prohibited, in part or in full. All third-party brands or copyrights mentioned in this manual are the property of their respective owners.

This product has a limited warranty of one year. Warranty may be voided by:

- Physical damage of the product
- Any damage caused by improper use, maintenance or storage
- Damage resulting from the use of incorrect power supplies
- Damage not related to the design of the product or the quality of its manufacture

Safety Precautions

The Video Transmission System

Do not block or obstruct air vents, as this may cause short circuits, fire or electric shocks. Turn the device off immediately if it comes into contact with liquids.

The Power Supply

The device may be used with batteries or AC-DC power supplies of the voltage specified on the device or in the enclosed documentation.

If batteries are used, please ensure that the batteries are compatible and have no cracks or leaks.

Please use the enclosed power adapter. When using a third-party power adapter, please ensure that the adapter conforms to the specifications of the device and has the correct polarity.

Remove the power supply if:

- The device will not be used for an extended period of time
- The power cable is damaged
- The exterior of the device is damaged.

Operating Environments

- Due to current regulations governing the use of radio-based systems, this device is authorised for indoor use with the pre-installed channels five and six (by law, "indoor use" is defined as use in a building or similar location in which the shielding will typically provide the necessary attenuation).
- Do not place the device on metallic surfaces, to ensure effective data transfer.
- Do not place the device on dirty or damp surfaces.
- Do not use the device in the proximity of water or in high humidity, near open fires or gas pipes, or near electrical mains.



AT	BE	CY	CZ	DK	EE	FI
FR	DE	EL	HU	IE	IT	LV
LT	LU	MT	NL	PL	PT	SK
SI	ES	SE	UK	BG	RO	HR

In all EU member states, operation of 5150-5250MHz is restricted to indoor use only.

Overview

The DC-Link- ULR1/LR2 is a high-performance WHDI video transmission system which transmits uncompressed video and audio signals up to 1200m(ULR1)/700m(LR2) with low latency (1 ms delay).

Due to the conscious decision not to implement DFS (Dynamic Frequency Selection), which is compulsory for outdoor use, the device has a longer range, greater stability and better usability than comparable systems, t

Transmitter and receiver both have 3G-SDI and HDMI connectors (Plug & Play). When a video source is attached, the transmitter automatically selects the input (SDI is prioritised). The receiver's 3G-SDI and HDMI outputs can be used simultaneously.

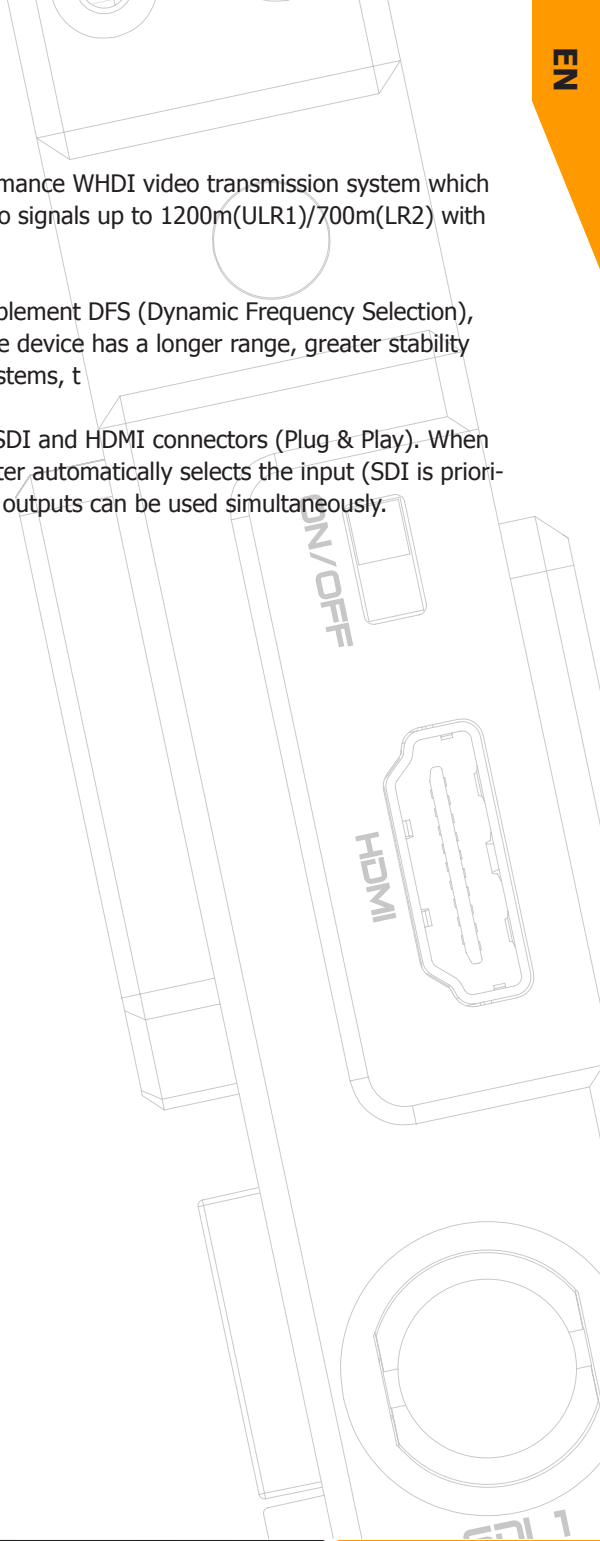

Characteristics

- **1200m (ULR1)/700m (LR2) Range**
Transmission ranges of up to 1000m are possible with good line-of-sight and optimum antenna positioning
- **Rapid and Reliable Connectivity**
The decision not to implement the DFS System compulsory for outdoor use, as well as the preinstalled transmission channels, mean there is no need for complex pairing procedures. In addition, transmission stability is increased
- **Real-Time Transmission**
With a latency of less than 1ms, the system is suitable for live monitoring applications
- **Uncompressed Transmission**
10-bit, 4:2:2 transmissions via 3G-SDI and HDMI without format conversion
- **Supports Formats up to and including 1080p 60Hz**
- **2- Channel Audio Transmission**
Embedded audio transmission on CH1 & CH2 via SDI and HDMI
- **License-free Frequency Band**
Functions in the license-free 5GHz ISM frequency range from 5.1-5.9GHz
- **Multicast Support**
1:1 or 1:n transmissions with up to four parallel systems
- **Metadata and Timecode Transmission**
- **AES-128 Encryption**
- **Metal Casing**
Transmitter and receiver are extremely durable
- **Variable Input Voltage**
Input voltage range from 9.0-18.0V DC allows the system to be operated with a variety of batteries or power supplies
- **Status Displays**
Status displays for DC power, video and RSSI signal strength
- **Mount**
1/4" tripod mount
- **Battery Adapter Plate**
Delivered with NPF/ V-Mount battery plates as standard
- **Plug-and-Play Design**
Ready to use without the need for complex configuration
- **1 Year Manufacturer's Warranty**

Product Description

Transmitter

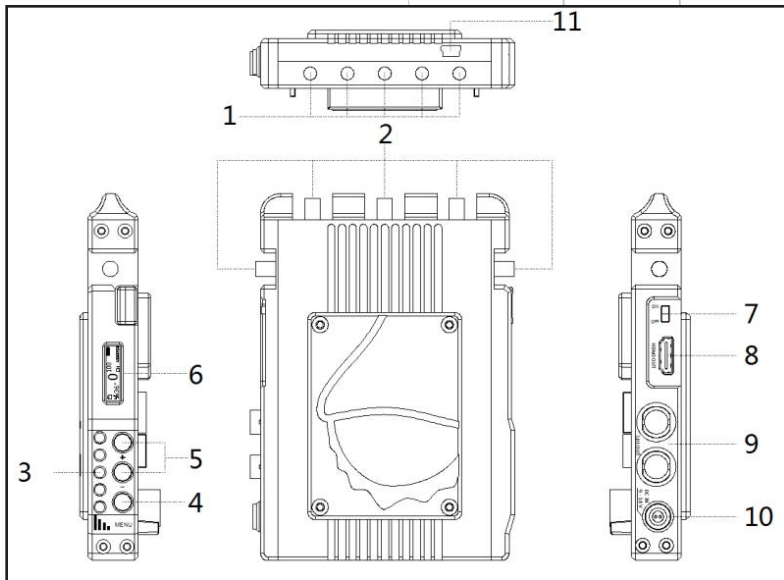

- 1) ¼" Tripod Mount
- 2) Antenna Connection: SMA (male) Connector
- 3) Menu Button: Unlock/lock screen
- 4) Control Button: Press to change the channels
- 5) LCD Screen: Display channel, power level, temperature info, OSD states.
- 6) ON-OFF: Power Switch
- 7) SDI-IN: 3G/HD/SD-SDI Input, (BNC Female Connector)
- 8) SDI LOOP-OUT: 3G/HD/SD-SDI Output, (BNC Female Connector)
- 9) HDMI-IN: HDMI Input (Type A Female Connector)
- 10) DC-IN: 9 – 18V DC
- 11) Mini USB: For firmware upgrade use.

Product Description

Receiver

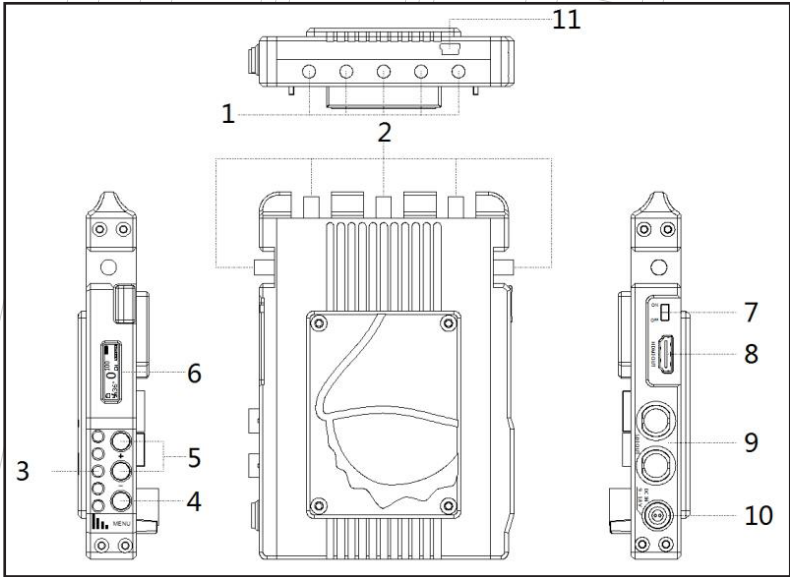

- 1) 1/4" Tripod Mount
- 2) Antenna Connection: RP-SMA (male) Connector
- 3) RSSI Status Display: Signal Strength
- 4) Menu Button: Unlock/lock screen
- 5) Control Button: Press to change the channels
- 6) LCD Screen: Display channel, power level, temperature info, OSD state.
- 7) ON-OFF: Power Switch
- 8) HDMI-OUT: HDMI Output (Type A Female Connector)
- 9) Dual SDI-OUT: 3G/HD/SD-SDI Output, (BNC Female Connector)
- 10) DC-IN: 9.0 – 18.0V DC
- 11) Mini USB: For firmware upgrade

Operation

Transmitter

1. Connect the two omni-directional antennas to the SMA male connectors.
2. There is a ¼" tripod mount at the base of the transmitter if required.
3. Use the enclosed 4-pin male-to-D-TAP cable to connect to a power supply with a suitable voltage.

Receiver

1. There is a ¼" tripod mount at the base of the receiver if required.
2. Use the enclosed 4-pin male-to-D-TAP cable to connect to a power supply with a suitable voltage.
3. Ensure you have selected the frequency that corresponds to that of the transmitter.

Signal Distribution

Connect the camera's SDI or HDMI output to the transmitter's SDI or HDMI input. If both SDI and HDMI inputs are active, the transmitter will prioritise the SDI signal.

Connect the receiver's SDI or HDMI output to the SDI or HDMI input of the monitoring/recording device. During active transmission, both the SDI and the HDMI output on the receiver can be used simultaneously.

Ensure that the antennas are connected firmly, that all other connections are stable, and that the batteries are suitable.

Antenna Positioning

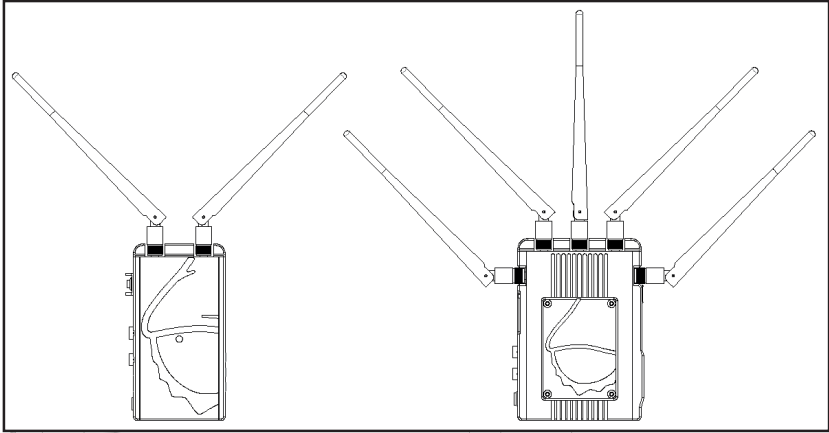

Position the antennas on transmitter and receiver as shown in the illustration. This ensures the best possible RF performance.

Install the transmitter and the receiver as high as possible (at least 2 metres above ground level) to maintain a good line-of-sight. During operation, try to keep the transmitter and the receiver at similar heights.

Avoid obstacles such as walls, trees, water and steel structures between transmitter and receiver.

The connection is at its strongest when the flat surfaces of the transmitter and receiver face each other.

Functions

OLED Display

The OLED Display shows the most important information on the Transmitter and the Receiver.

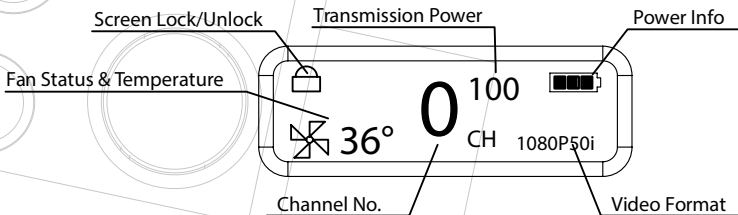

Choosing a Channel

1. To choose a channel on the **Transmitter** press and hold the "MENU" button for 2 seconds, until unlock icon is shown "🔓" on the OLED.
2. Press the "+" or "-" button to select the desired channel, then press the "MENU" button to confirm.

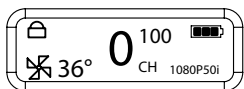

1. To choose a Channel on the **Receiver**, press the "MENU" button and select the channel with the "+" or "-" button, then press the "MENU" button to confirm.

The system functions on 10 channels in the license-free 5 GHz ISM frequency band. Both transmitter and the receiver have a frequency selector with positions from 0-9. The transmitter and the receiver have to be set on the same channel to work. If several systems are used at once, then one should only use every second channel. A maximum number of 4 systems can be used simultaneously.

DC-SCAN

The DC-SCAN is a spectrum analyzer of the 5 GHz band and shows how busy the respective channels are. Choose a free channel for proper performance.

To enter the DC-SCAN, press the "-" button for 3 seconds. The frequency scanner is only available on your HDMI output. To switch the DC-SCAN off press the "-" button again for three seconds.

Channel 0 in the DC-Scan mode displays the **antenna function monitor**. If the antenna green everything is fine. If it is red there is a problem with the antennas.

OSD

The OSD is important when you configure your device or if you need status information. In live situations the OSD might be annoying. The OSD can therefore be switched off on the **receiver**. To switch it off, please press the "MENU" button three times, and then press the "+" button, confirm it by pressing the "MENU" button again. An indicator on the OLED display of the receiver shows you the OSD state. To switch it on again, press the "MENU" button three times, and then press the "+" button, confirm it by pressing the "MENU" button again and check the state on the OLED display of the receiver.

Reducing Transmission Power

To reduce the transmitting power, press the transmitter and "+" or "-" buttons at the same time.

Fan Control

The fan control allows the user to reduce the volume of the fan during audio recording. To switch the fan on the receiver off or on, press the "MENU" button twice. Press the "+" button, then confirm selection with the "MENU" button. A indicator on the OLED display of the receiver shows you the fan state.

On the **transmitter** press the "+" button and the "-" button together for 3 seconds until the OLED display shows the fan menu. To switch the fan ON press the "+" button, to switch it OFF press the "-" button and confirm your selection with the "MENU" button.



Warning!



Switching off the fans may be required in some situations, but doing this permanently is not recommended. This will effect the life-time of your wireless equipment. To prevent your device from damage, fans switch on automatically after a reboot. If the temperature exceeds 75 degrees Celcius, please switch on the fans instantly. Any damage caused by over-heating voids warranty.

Cinema Mode

The cinema mode is an automatic mode that only works via SDI signal. The fan is switched off at the start of recording via the record trigger of the camera. When the recording is finished the fan starts automatically.

RSSI Display

The RSSI (Received Signal Strength Indicator) display shows the strength of the signal, allowing the operator to ensure the system is working properly.

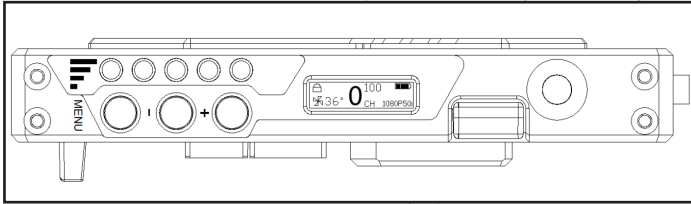

Display	Status	Description
RSSI	0-1 LEDs	Radio signal strength is weak and artefacts are visible in the video signal
	2-3 LEDs	Radio signal strength is normal and video quality is good
	4-5 LEDs	Radio signal strength is very strong and video quality is very good

Establishing a Connection

Once all previous steps have been performed, turn on the transmitter and the receiver using the power switch.

Once the transmitter recognizes a video input, the video format will be displayed on the LCD screen.

It takes between 10-30 seconds for the transmitter to connect to the receiver. During this brief period, the receiver's video out displays "Waiting for connection".

Maintenance

Please do not attempt to repair, modify or alter these devices under any circumstances. Clean the devices with a soft, clean, dry and lint-free cloth. Do not open the devices, they contain no user-serviceable parts.

Storage

The devices can be stored at temperatures between -20°C and 60°C. For long-term storage, please use the original transport case and avoid environmental conditions such as high humidity, dust, or excessively acidic or base surroundings.

Warning!

To ensure your own safety, please use only high-quality brand name batteries, and follow the safety instructions provided by the manufacturer.

Troubleshooting

	Possible Cause	Possible Solution
No video output	Lack of power	Check power supplies of transmitter and receiver and ensure that all cables are connected properly and that there is sufficient power.
	Antennas	Ensure antennas are not damaged and are firmly connected. Please use the DC-Scan to check.
	Video connection cable	Examine the transmitter's "Video" LED display. If the LED is dark, check the HDMI or SDI connection cable.
	Frequency selection	Ensure that the transmitter and receiver are set to the same channel.
	Unsupported video format	Make sure you using a supported video format.
Inadequate video quality	Connections	Ensure that all SDI or HDMI cables are firmly connected.
	Range is too great or signal is obstructed	Check how many "RSSI" LEDs are lit on the receiver. For decent quality, at least 2-3 LEDs should be lit. If only one is lit, the signal is weak and the distance between transmitter and receiver should be reduced. Alternatively, obstacles between the devices should be removed or another channel selected.
	Radio signal is experiencing interference	Open the DC-Scan and choose a free channel.

Technical Specifications

	Transmitter	Receiver
Connections	1x SDI Input (BNC female) 1x SDI Output (BNC female) 1x HDMI Input (Type A female) 2x Antenna (RP-SMA male) 1x DC Input (4-pin female)	2x SDI Output (BNC female) 1x HDMI Output (Type A female) 5x Antenna (RP-SMA male) 1x DC Input (4-pin female)
Power	9.0 – 18.0V DC	9.0 – 18.0V DC
Power Consumption	< 8 W	< 8 W
Dimensions (LxBxH), w/o Antennas	143.5 x 74.5 x 21.4mm	147.8 x 100 x 20mm
Weight	380g	540g
Supported Video Formats	1080p(60, 59.94, 50, 30, 29.97, 25, 24, 23.98) 1080i (60, 59.94, 50) 720p (60, 59.94, 50) 576i (50) 480i (59,94)	1080p(60, 59.94, 50, 30, 29.97, 25, 24, 23.98) 1080i (60, 59.94, 50) 720p (60, 59.94, 50) 576i (50) 480i (59,94)
Audio Format	SDI Embedded 2 Channel Audio 24bit/48kHz	SDI Embedded 2 Channel Audio 24bit/48kHz
Displays	0.91 inch OLED panel	0.91 inch OLED panel, 5 LEDs for RSSI indicator
Frequencies	5190, 5230, 5755 and 5795MHz	5190, 5230, 5755 and 5795MHz
Transmitting Power	Less than 20 dBm	-
Receiver Sensitivity	-	- 75 dBm
Bandwidth	40MHz	40MHz
Modulation mode	5G WIFI:OFDM	5G WIFI:OFDM
Max. of Transmit power	5G WIFI: 21.96dBm	5G WIFI: 21.96dBm
Maximum Antenna Gain	5G WIFI : 3.3dBi	5G WIFI : 3.3dBi
Operating Temperature	0 – 40°C (Operation) -20 – 60°C (Storage)	0 – 40°C (Operation) -20 – 60°C (Storage)
Certification	CE	CE

Country-specific operating license

Position (Kanal)	Frequenz	Europa	USA	Canada	Russland	Japan	China	Turkei
0	5550 MHz	x	x	x	✓	x	x	x
1	5590 MHz	x	x	x	✓	x	x	x
2	5630 MHz	x	x	x	✓	x	x	x
3	5670 MHz	x	x	x	✓	x	x	x
4	5150 MHz	x	x	x	✓	x	x	x
5	5190 MHz	Indoor	Indoor	Indoor	✓	Indoor	✓	Indoor
6	5230 MHz	Indoor	Indoor	Indoor	✓	Indoor	✓	Indoor
7	5270 MHz	x	x	x	✓	x	x	Indoor
8	5310 MHz	x	x	x	✓	x	x	Indoor
9	5510 MHz	x	x	x	✓	x	x	x

Before operating the radio system, please check the frequency regulations in the respective country.

Included Accessories

1x Transmitter

1x Receiver

9x External Antennas (can be ordered seperately)

2x DC Adapter cables from Anton Bauer (D-Tap) (m) to 4-pin DC connector(m)

2x Power supplies

1x Magic-arm with 1/4" Screw

1x Hot-shoe adapter

1x Quickstart Guide

Notes

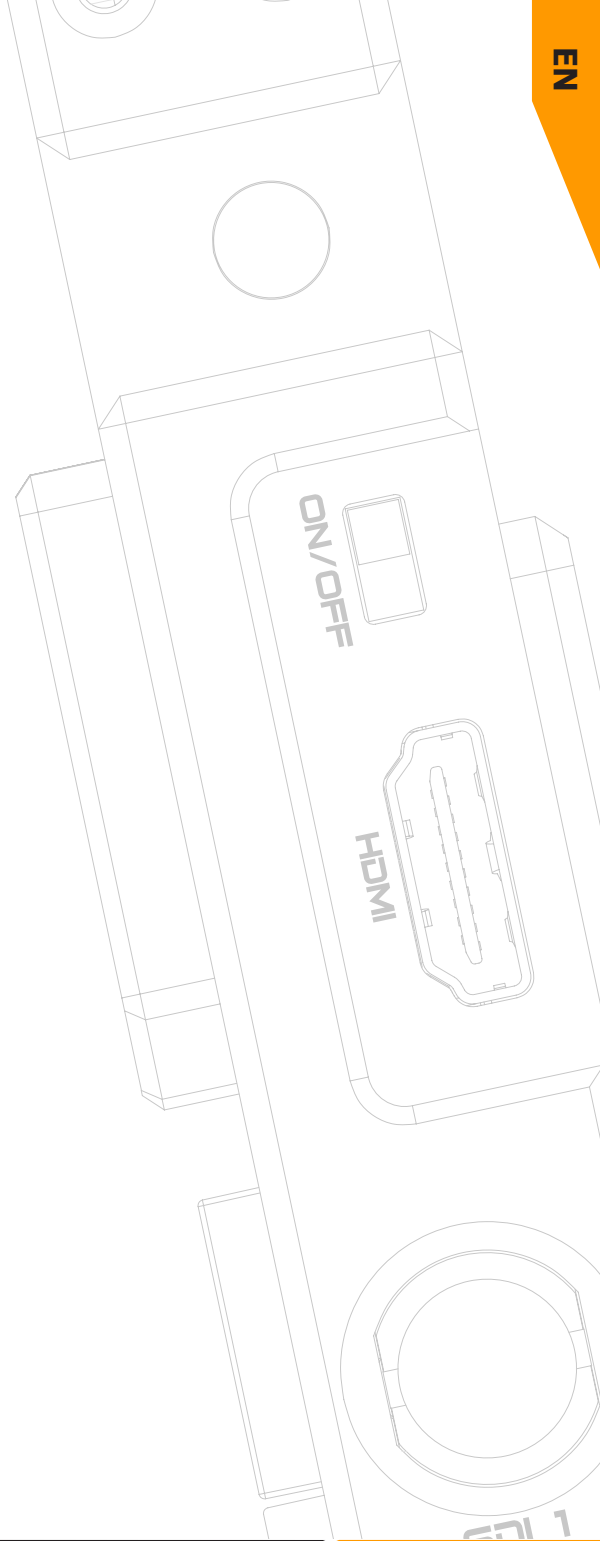



DwarfConnection OG
Münzfeld 51
A-4810 Gmunden, Austria
office@dwarfconnection.com
www.dwarfconnection.com

Errors and omissions excepted.